

RELY ON EXCELLENCE

# Leading Innovation in Sustainable Sealing Solutions

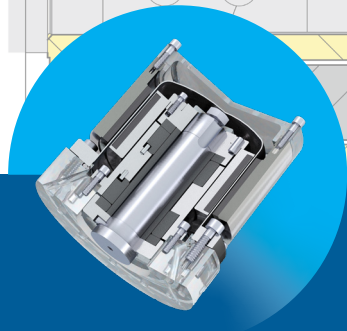
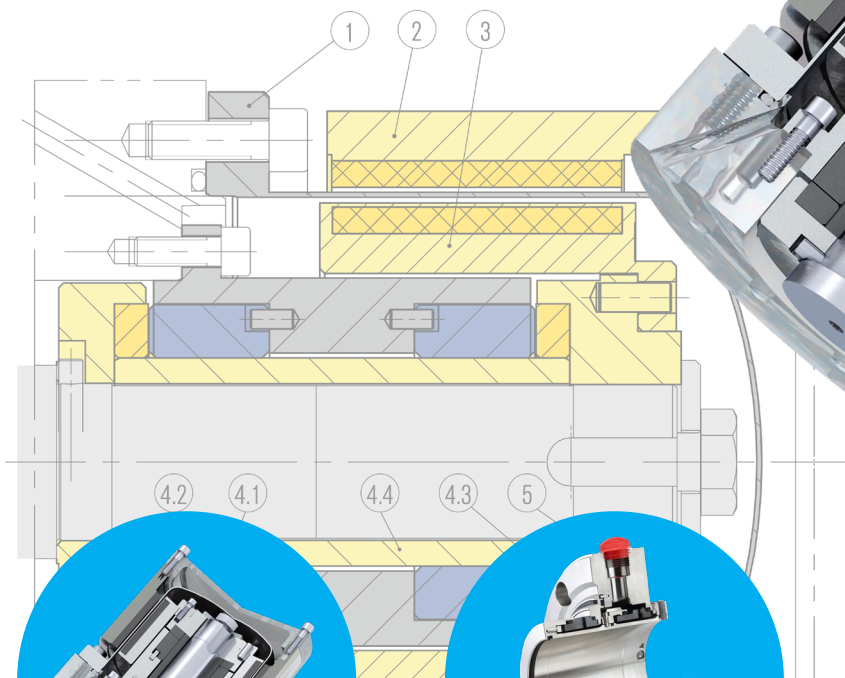

## Magnetic Couplings

The EagleBurgmann eMAK/MAK66 and MAK685 Magnetic couplings, offer hermetic sealing solutions for process pumps and equipment, meeting appropriate design standards and eliminating the emission of hazardous or volatile media to atmosphere. Complete your new or upgraded design with the LMF1 Process Lubricated Bearing Assembly for trouble free running.

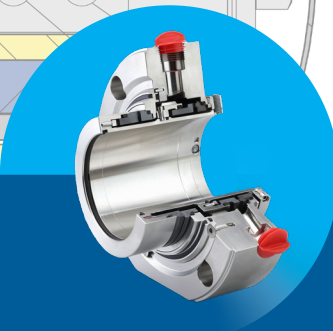

## API682-S

API682-S from EagleBurgmann is a fully qualified API682 seal for Category 1 applications (ISO/ANSI Pumps), with a wide choice of metallurgy, features including Balanced Faces, Multipoint Injection, Protected Springs and can be employed in almost any process condition. Available as API682-T for Dual Seal applications.



## H75A4-B

The latest derivative of the EagleBurgmann stalwart the H75A4-B, Dual Back-to-Back seal, meets API682 Category 2/3 requirements, is engineered with Integrated Pumping Device, Reverse Pressure Capable Faces, Springs out of the Product, and when combined with an EagleBurgmann Barrier Fluid System provides a Safe installation with unsurpassed 40bar reliability.



[eagleburgmann.com](http://eagleburgmann.com)  
[info@eagleburgmann.com](mailto:info@eagleburgmann.com)

**EagleBurgmann**<sup>®</sup>

a member of **EKK** and **FREUDENBERG**